



**LIFT
TYPE**

KELLY
**PLANTER
ATTACHMENT**



MODELS 12-9, 10, 11 & 12



ASSEMBLY and OPERATING

Instructions

DEARBORN MOTORS CORPORATION — DETROIT 3, MICHIGAN

DESCRIPTION

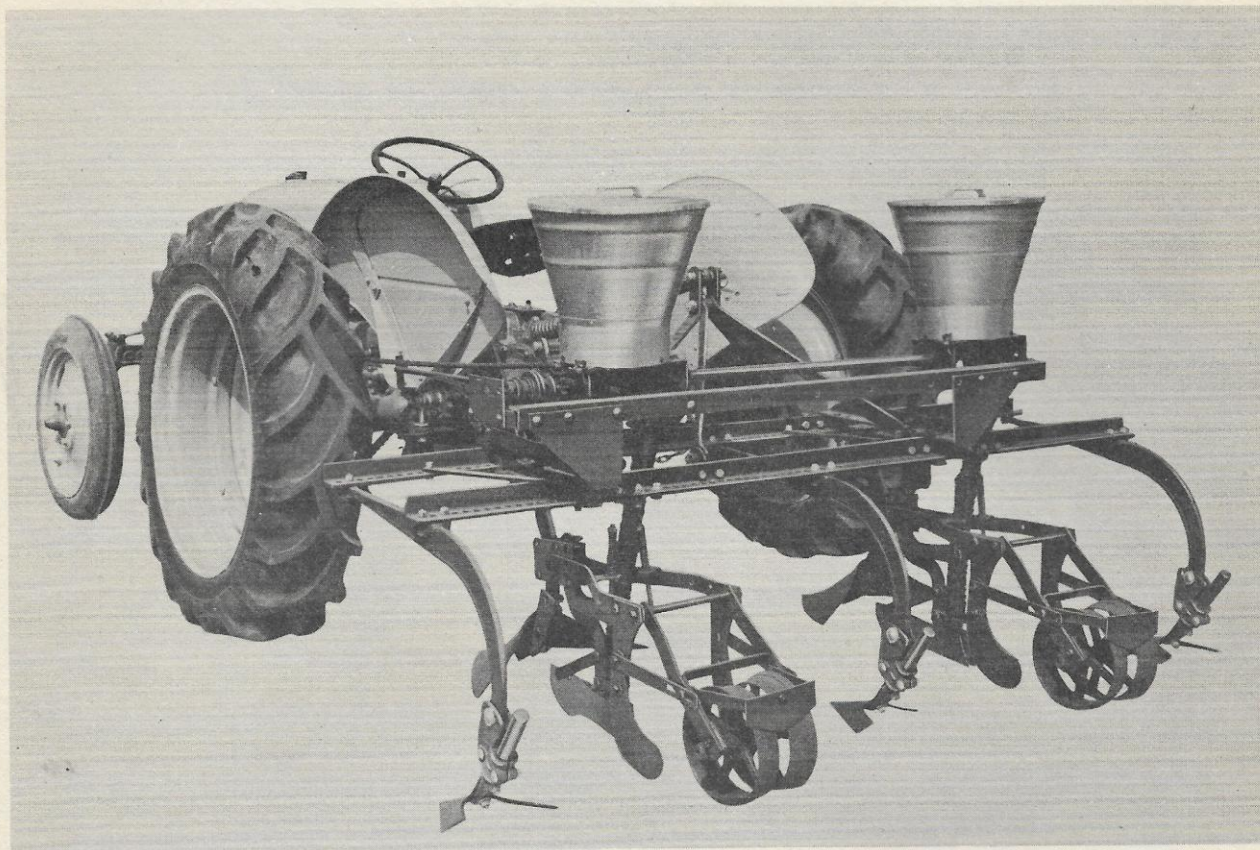

Figure 1

Kelly Planter Attachment Mounted on Rigid Shank Cultivator

The Kelly Planter Attachment is a two-row combination cotton and corn planter attachment designed so that it can easily be mounted on the frame of either the Dearborn Rigid Shank Cultivator or the Dearborn Middlebuster.

The necessary Drawbar stabilizer kit for use with the planter attachment is sold separately.

The planter attachment is equipped with two seed hoppers which have a capacity of approximately $\frac{3}{4}$ bushel each. Two cotton seed plates, twelve seed plates for corn, beans and peas, and a seeding mechanism with automatic throw-out are provided with each planter attachment.

This planter attachment is available in four models of covering frames (see Figure 3) designed for use in different types of soil. Openers and coverers provided with the covering frames are interchangeable so that the desired combination can be obtained to meet a wide variety of planting conditions.

The planter can easily be set to plant rows from 36 to 42 inches apart and adjusted to drop seeds in spacings from 5 to 44 inches.

A fertilizer attachment, duplex hoppers, bedding sweeps, depth slides and a variety of seed plates are available for this planter at extra cost from your Ford Tractor and Dearborn Farm Equipment dealer.

Copyright 1948 Dearborn Motors Corporation—Detroit 3, Mich.

ASSEMBLY

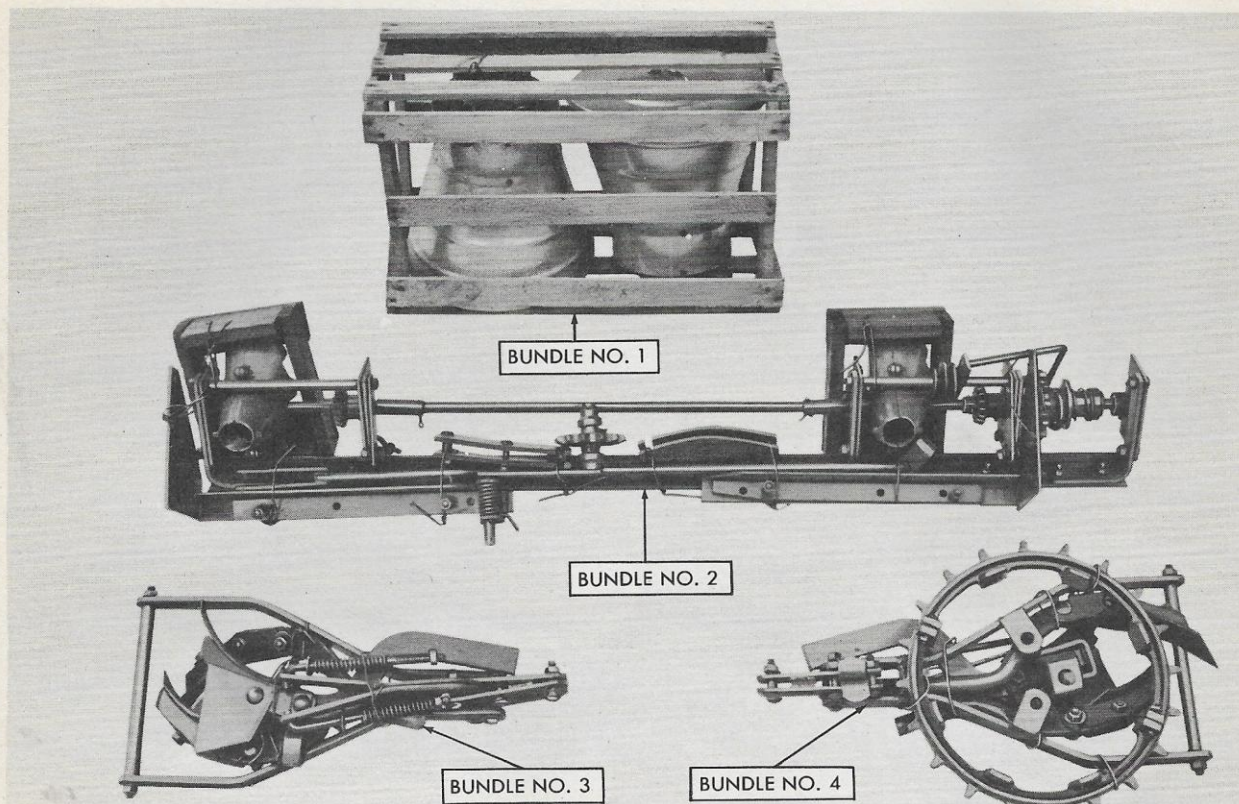

Figure 2

Kelly Planter Attachment Bundled for Shipment

NOTE: Assembly of the Kelly Planter Attachment is the responsibility of the Ford Tractor and Dearborn Farm Equipment dealer. The implement should be delivered completely assembled. The following instructions are for guidance in case of need.

BUNDLE INFORMATION

The Kelly Planter attachment is shipped in four bundles as listed below. Check shipment against this list and Figure 2 to be sure all parts are received.

Bundle No. 1

One crate containing two seed hoppers, two seed tubes, twelve seed plates, one

drive chain, two cotton seed plates and tube containing instruction manual.

Bundle No. 2

One planter main frame with two angle supports, two sweep brackets, one clutch throwout rod, one throwout rod bracket and one chain idler wired together.

Bundle No. 3

One covering frame.

Bundle No. 4

Covering Frame with tractor drive sprocket wired to it.

NOTE: See Figure 3 for covering assemblies for each of the four models.

ASSEMBLY

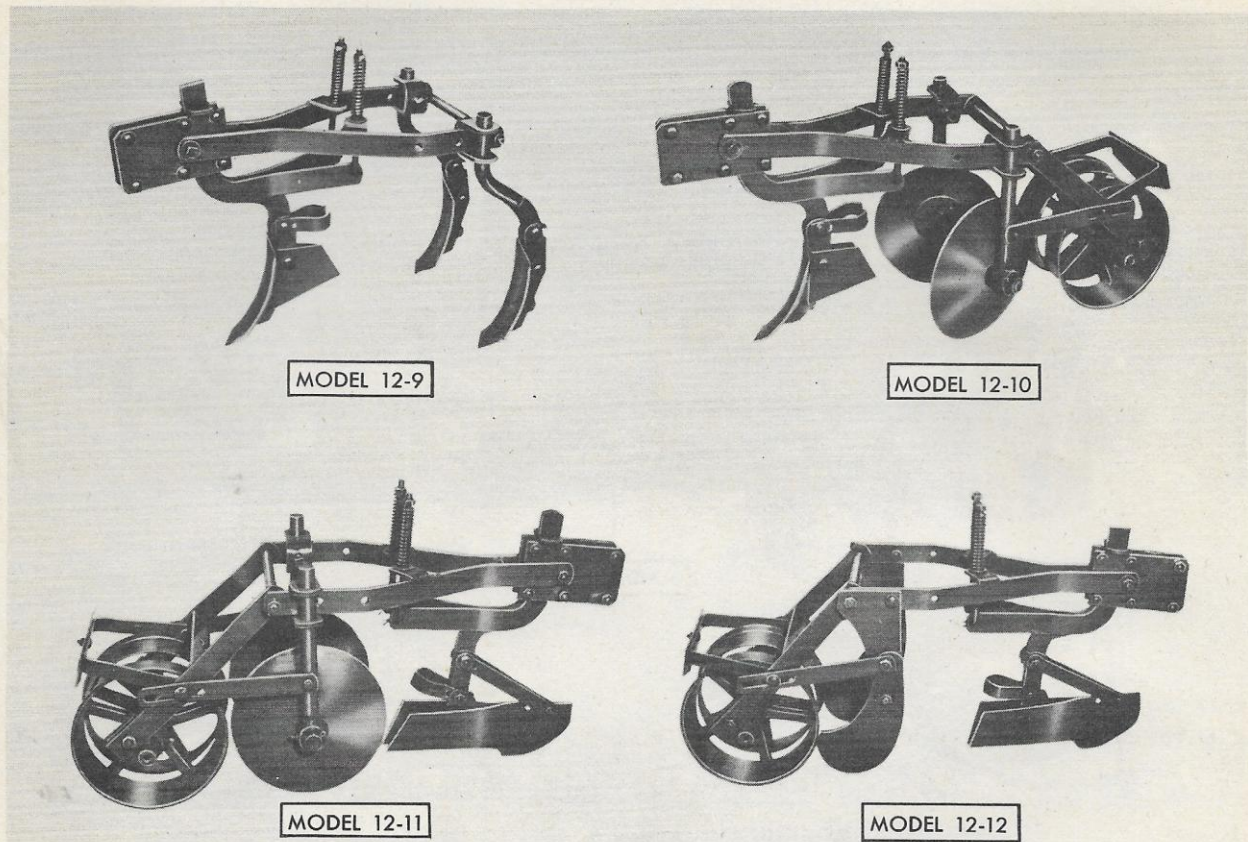

Figure 3

Kelly Planter Covering Frames Assembled

PROCEDURE FOR MOUNTING PLANTER ON RIGID SHANK CULTIVATOR

1. Set the tractor rear wheels at 72 inches to plant rows 36 inches apart and at 76 inches to plant rows 38, 40 and 42 inches apart.
 - a. Set the front tractor wheels according to seed bed.
2. Attach the drive sprocket (1) to the tractor left rear brake drum as shown in Figure 4, and secure with the four bolts and nuts provided.
 - a. Remove the rear bolt (3), Figure 4, holding the tractor left fender and attach the throw-out rod bracket (2), replace the bolt, leaving the nut off at this time.
 - b. Remove the nut from the left fender front bolt and attach the stabilizer bracket (4) under the axle as shown in Figure 4 and secure with nuts.
 - b. Attach the stabilizer bracket under the right axle in the same manner.

ASSEMBLY

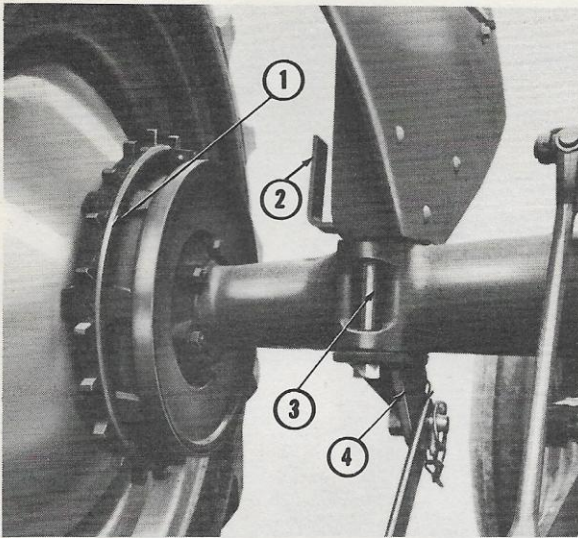

Figure 4

Drive Sprocket, Throwout Rod Bracket and Stabilizer Brackets Attached

4. Attach the cultivator to the tractor using the standard three point hook up.
 - a. Attach the stabilizer bars to the brackets

under the tractor rear axles and to the cultivator lower link pins.

5. Remove the cultivator fenders, the rolling fin and the second, fourth, and fifth shanks from each end of the cultivator.

NOTE: Sweeps (6) and shanks (1), (5) and (7) as shown in Figure 5 may be used for cleaning the furrows.

6. Attach the two forward shanks (2) and (4), Figure 5, to the cultivator frame at the desired row width. Be sure the shanks are spaced equally from the center of the frame.
7. Assemble the covering frames concerned as shown in Figure 3.
8. Attach one covering assembly to the cultivator shanks (2) and (4), Figure 5, as follows:
 - a. Remove the two carriage bolts (3), Figure 5, from the front of each clamp bracket plate.

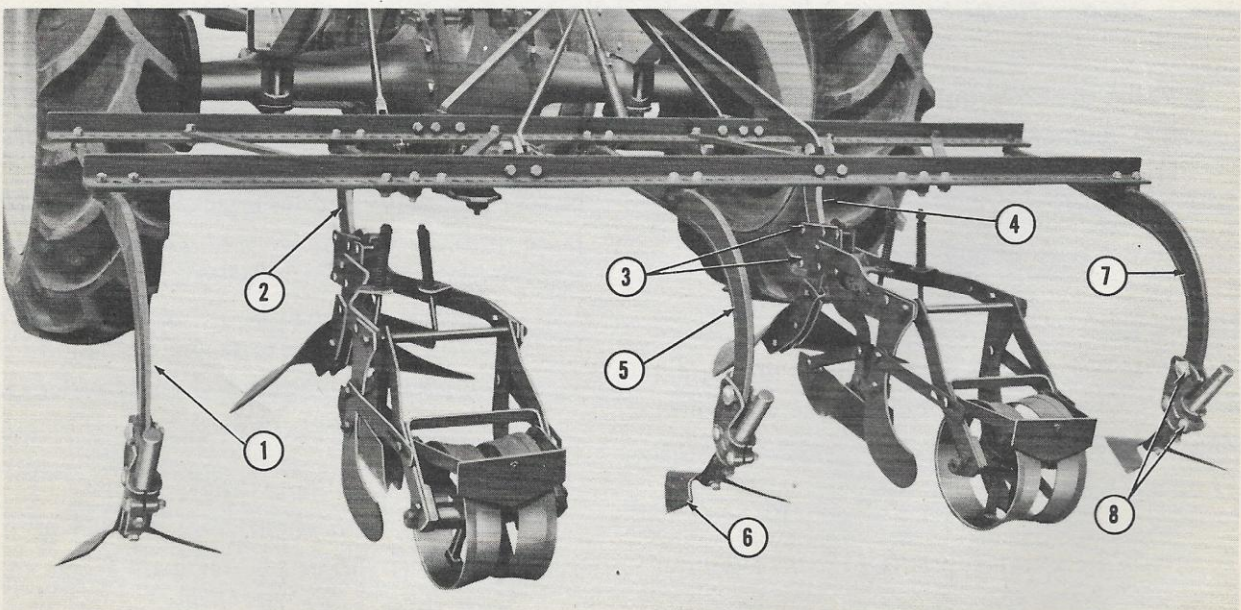

Figure 5

Covering Frames Attached to Cultivator Shanks

ASSEMBLY

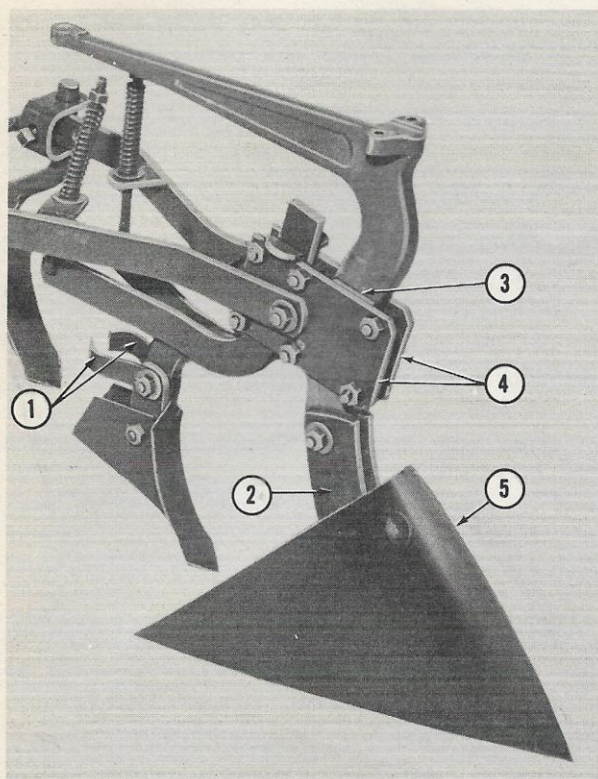

Figure 6

How to Attach a Planter Sweep to Cultivator Shank

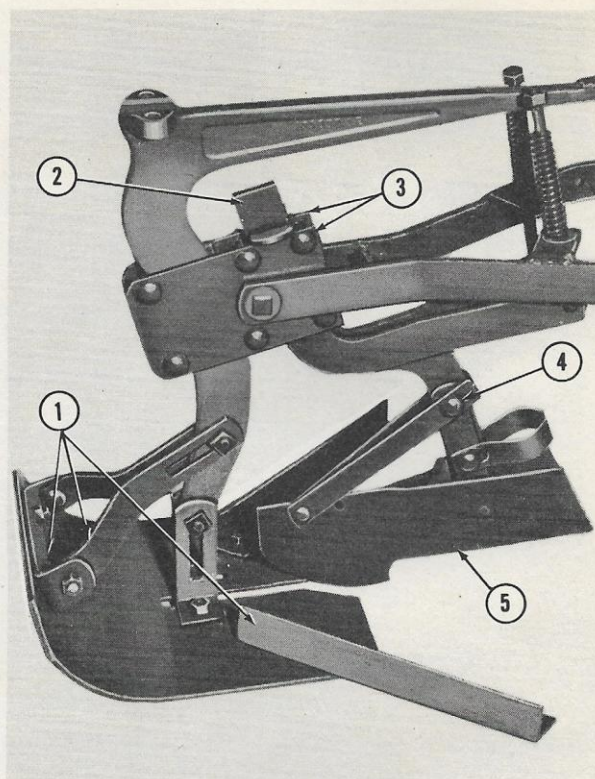

Figure 7

Kelly Depth Slide Attached

- b. Place the covering frames on the shanks (2) and (4) as shown in Figure 5 with the shank between the clamp bracket plates. Replace the carriage bolts (3) and secure with nuts.

NOTE: Each clamp bracket plate (4) has a welded spacer (3) as shown in Figure 6. To attach the covering assemblies to a cultivator shank, the plates (4) must be assembled with the spacers inside.

9. Attach the sweep brackets (2) and a planter sweep* of the type shown at (5), Figure 6, to the shanks (2) and (4), Figure 5, for planting flat turned or pre-listed land, or a

Kelly depth slide (1), Figure 7, for surface planting.

NOTE: The depth slide is available at extra cost from your Ford Tractor and Dearborn Farm Equipment Dealer.

10. Place the planter main frame (5), figure 8, on the ground and attach the left and right angle support as follows:

- a. Bolt the left hand angle support (7), Figure 8, with chain idler welded to it, to the left end of planter main frame (5) with three bolts (6) provided on main frame angle. Secure with lock washers and nuts as shown in Figure 8, rear view.

*Sweep shown in Figure 6 is not sold by Dearborn Motors Corporation but is available through other sources.

ASSEMBLY

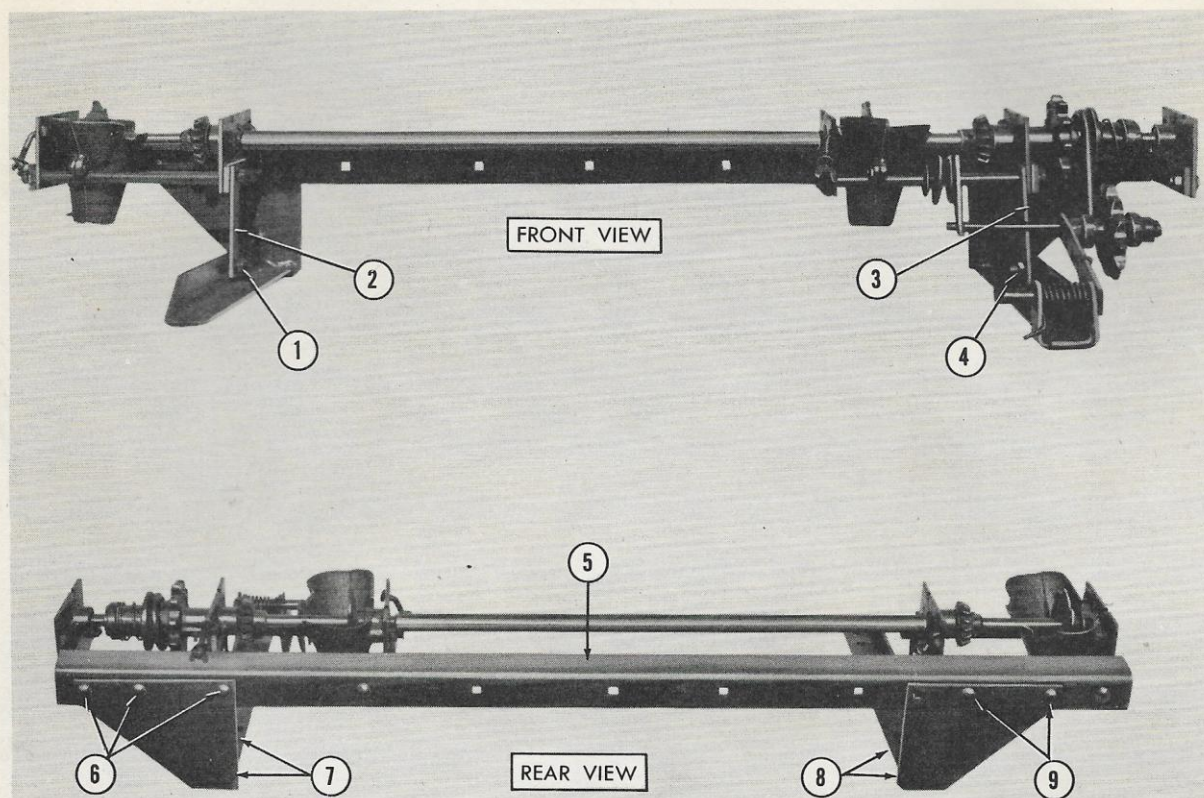

Figure 8

Main Planter Frame and Supports

- b. Bolt the right hand angle support (8) to the right end of planter main frame (5) with two bolts (9), as shown in rear view, Figure 8. Secure with lock washers and nuts provided on the main planter frame angle.
 - c. Bolt the right hand hopper forward support (2) to the right hand support angle with bolt and nut (1) provided, as shown in Figure 8, front view.
 - d. Bolt the left hand hopper forward support (3) to the left hand support angle with bolt and nut (4) provided, as shown in Figure 8, front view.
11. Attach the planter main frame assembly to the cultivator frame as follows:
 - a. Remove the lower clamp bars (5), Figure 9, and long bolts from the right and left main frame support angles.
 - b. Place the planter main frame assembly (4), Figure 9, on top of the cultivator frame so the forward end of each support angle (3) and (6) rests on the front angle (1) of the cultivator frame as shown.

ASSEMBLY

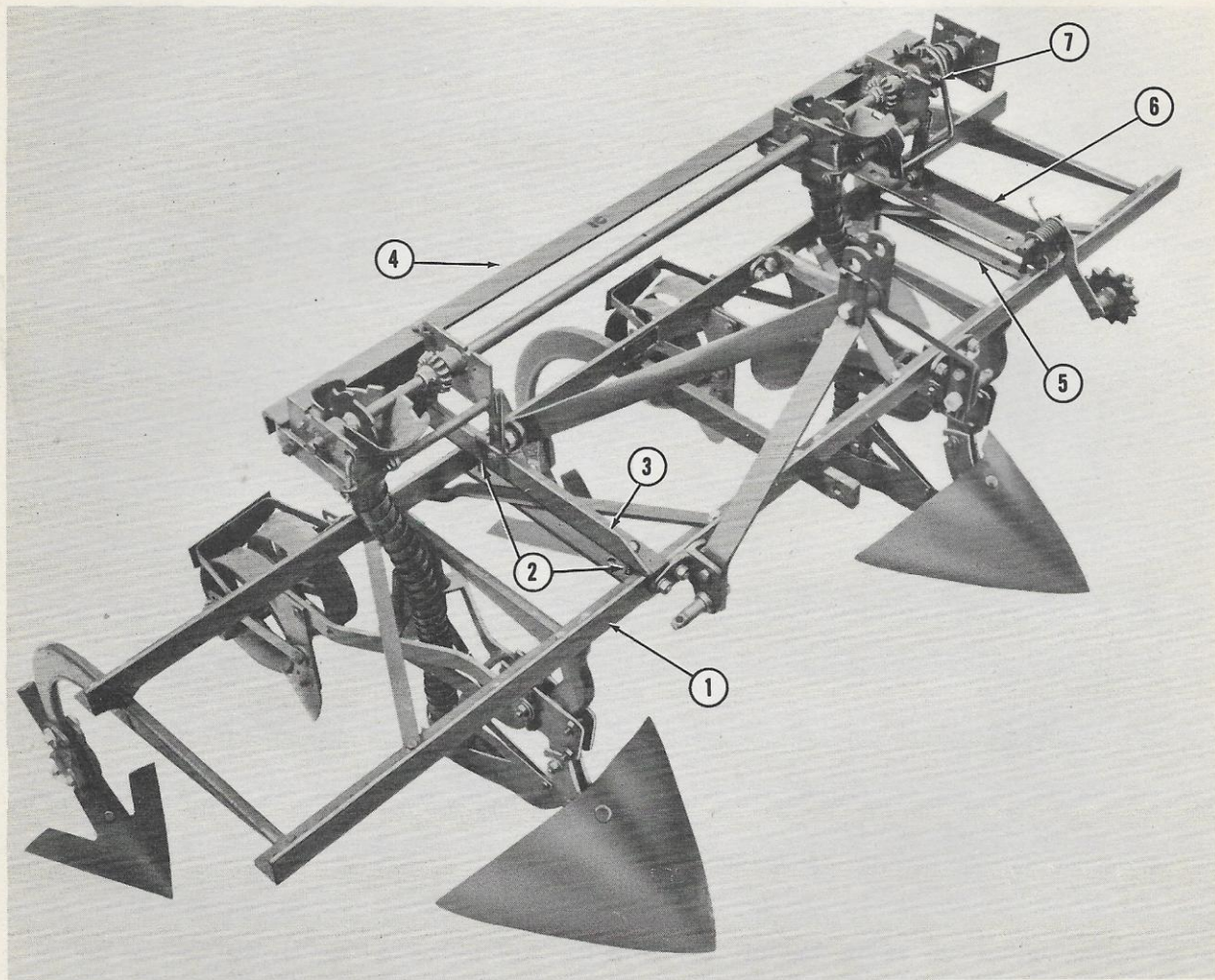

Figure 9

Planter Main Frame Assembly Attached to Cultivator Frame

- c. Position the planter main frame assembly on the cultivator frame so the clutch sprocket (7), Figure 9, is aligned with the drive sprocket on the tractor left rear brake drum.
 - d. Insert the long bolts (2), Figure 9, through the support angle (3) and (6) as shown.
 - e. Replace the lower clamp bars (5) under the cultivator frame angles as shown in Figure 9 and secure with nuts.
12. Place the drive chain (10) on the clutch sprocket (8), Figure 10, and run forward over the drive sprocket (2) on the tractor brake drum.
 - a. Remove extra chain links as necessary to give the chain proper length and tension.
 - b. Link ends of the chain together. Be sure slack side of the chain is over the clutch shift bar (9), Figure 10.

ASSEMBLY

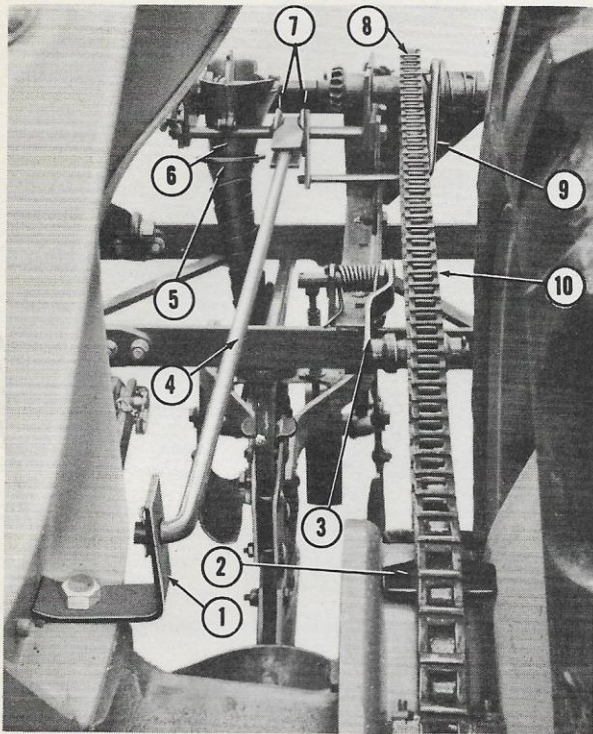

Figure 10

Drive Chain and Clutch Throwout Rod Attached

c. Position the chain idler (3) forward and under the slack side of the chain as shown in Figure 10.

13. Insert the tapered end of the clutch throwout rod (4), Figure 10, between the two large washers (7) on the left hand hopper horizontal support.

a. Insert the forward end of the clutch throwout rod (4) in the hole on the bracket (1) as shown in Figure 10 and secure with the cotter pin.

14. Place the collar end of each grain tube (5), Figure 10, on each grain spout (6). Push the collar up and turn to the right to lock it in place.

a. Secure the lower end of each grain tube with the clamp (1), Figure 6, provided on each opener.

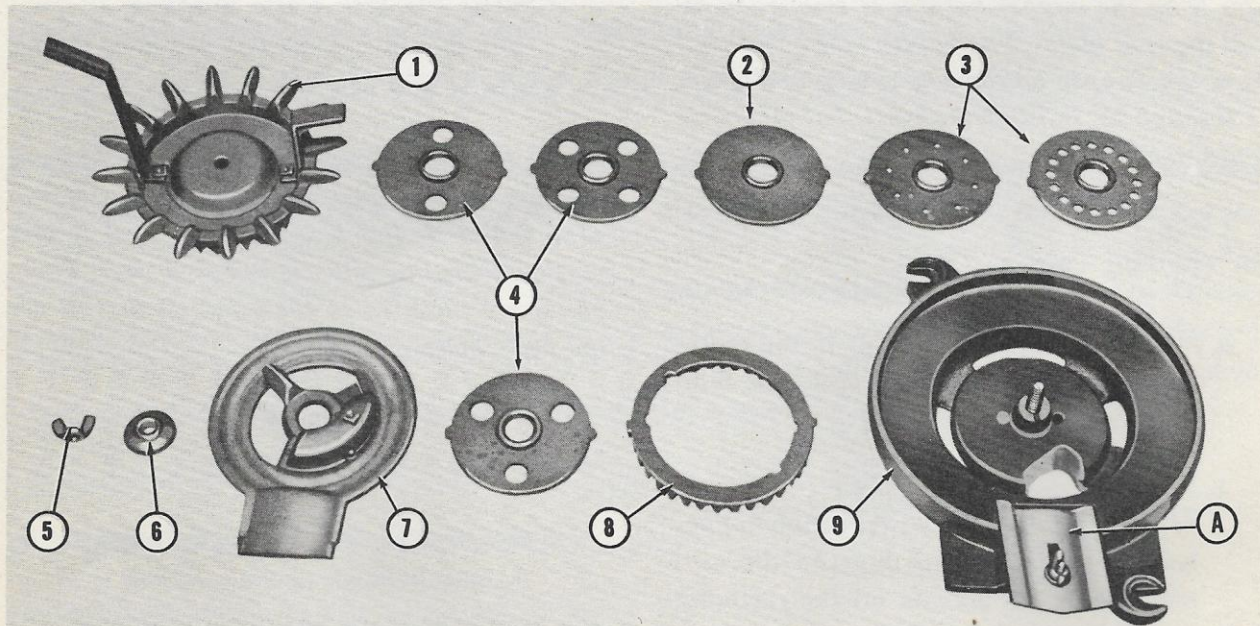

Figure 11

Layout of Hopper Bottom and Seed Plates

ASSEMBLY

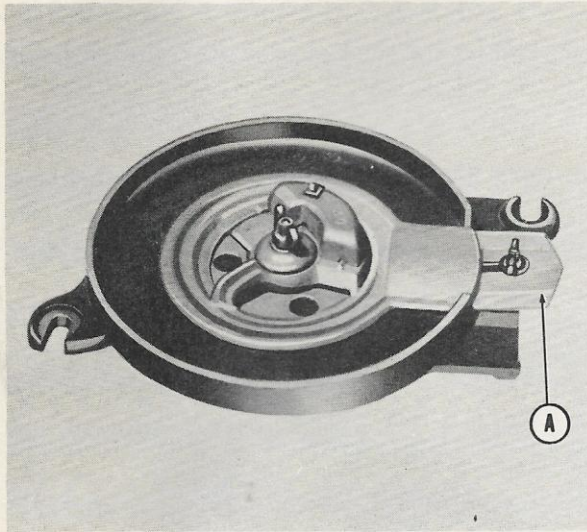

Figure 12

Hopper Bottom Assembled for Planting Corn

15. Assemble the seed hopper bottoms as explained below.

NOTE: It is not necessary to remove the hoppers from the hopper bottom assemblies to install the seed plates. The hoppers were removed from the hopper bottoms as shown in Figures 11 through 15, to illustrate parts that otherwise could not be seen.

For Planting Corn:

- a. Place the retaining ring (8) in the center of the can bottom (9), Figure 11, with the gear teeth down.
- b. Place the desired corn plate (4), Figure 11, on the bolt in the center of the hopper bottom so the driving lugs on the seed plate fit in the notches on the retaining ring.
- c. Position the cut-off assembly (7), Figure

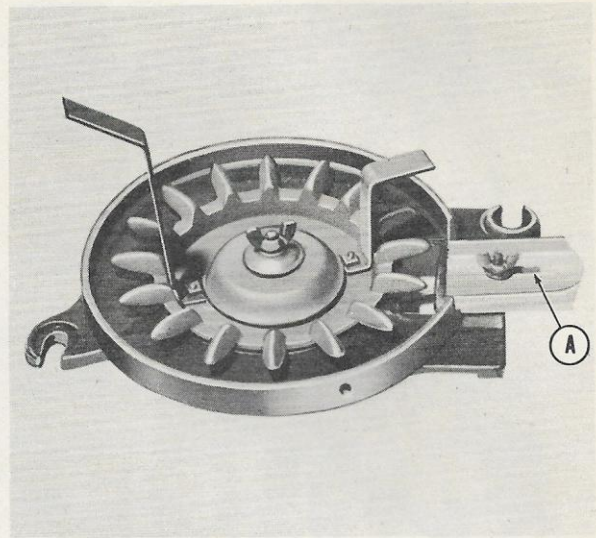

Figure 13

Hopper Bottom Assembled for Planting Cotton

11, on top of the seed plate and secure with the collar (6) and wing nut (5) as shown in Figure 12.

- d. When planting maize, sorghum or peas close the slide gauge (A) as shown in Figures 11 and 12.

NOTE: One pair of corn and pea plates (3) and one pair of blank plates (2), Figure 11, are also provided with the planter. The blank plates may be drilled to suit selected seed sizes. These plates are installed in the same manner as are the corn plates.

For Planting Cotton:

- a. Place the cotton plate (1), Figure 11, on the machine bolt in the center of the hopper bottom and secure with the collar (6) and wing nut (5). Figure 13 shows this unit assembled.

ASSEMBLY

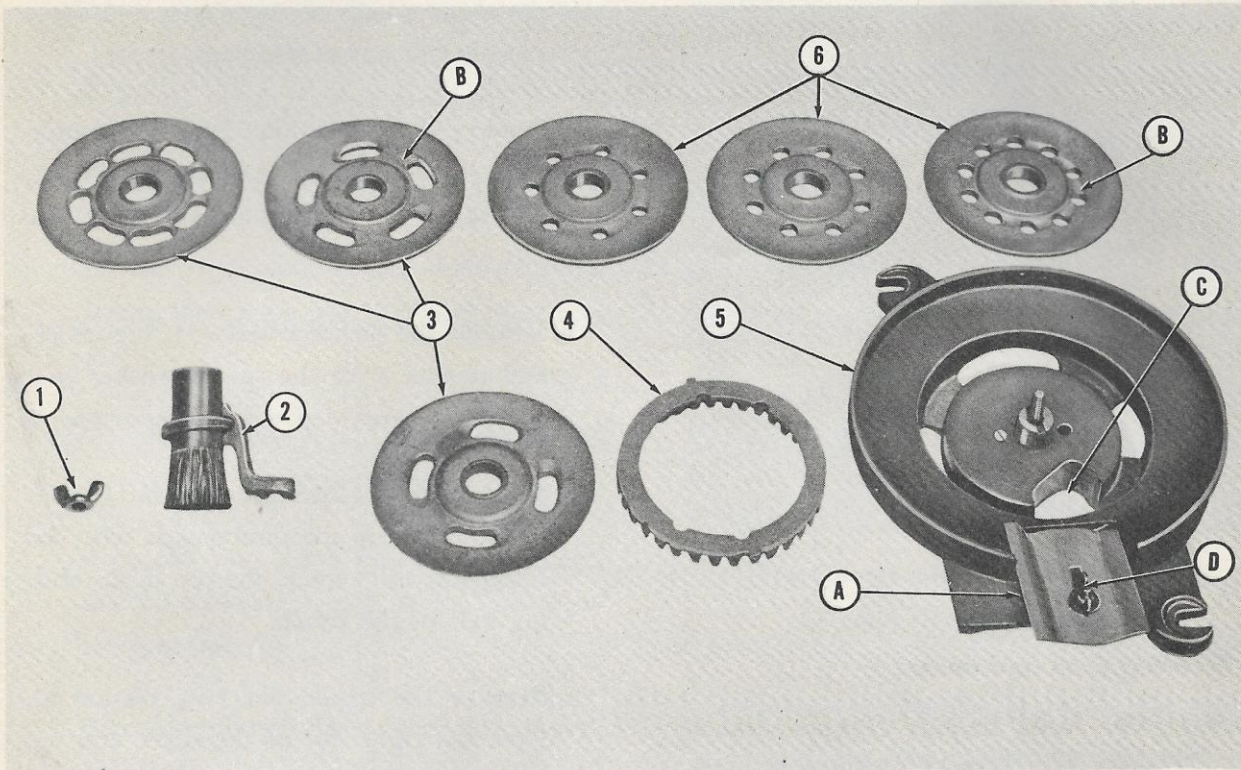

Figure 14

Peanut Attachment Model 12-13

b. Close the slide gauge (A), Figure 13, until it almost touches the picker wheel and secure with the wing bolt.

For Planting Peanuts:

NOTE: The Kelly Peanut Attachment Model 12-13, is extra equipment available at additional cost from your Ford Tractor and Dearborn Farm Equipment dealer. It consists of three sets of plates for planting shelled peanuts (6), Figure 14, three sets of plates for planting unshelled peanuts (3), and a peanut brush (2) as shown in Figure 14. To assemble the seed hoppers for planting peanuts proceed as follows:

a. Place the retaining ring (4) in the center

of the hopper bottom (5), Figure 14, with the gear teeth down.

b. Place the desired peanut plate (3) or (6), Figure 14, on the bolt in the center of the hopper bottom with the beveled holes (B), up.

c. Place the peanut brush (2), Figure 14, on the machine bolt in the center of the hopper bottom, position the brush over the seed outlet (C) and secure with the wing nut (1).

d. Close the slide gauge (A) and secure with the wing nut (D), Figure 14.

ASSEMBLY

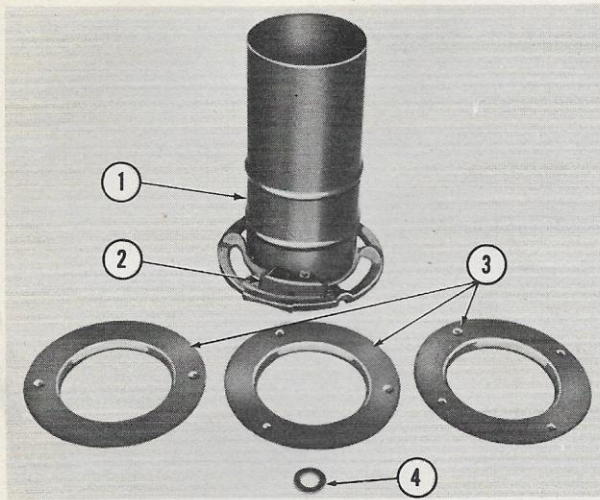

Figure 15

Duplex Hopper Attachment Model 12-17

For Planting Corn and Beans:

NOTE 1: *The Kelly Duplex Hopper Attachment, Model 12-17, is extra equipment available at additional cost from your Ford Tractor and Dearborn Farm Equipment dealer.*

NOTE 2: *The Duplex Hopper Attachment shown in Figure 15 consists of one pair of hoppers, three pairs of bean plates and two washers to replace the picker wheels. This attachment is used for planting corn and beans at the same time.*

NOTE 3: *It is necessary to remove the picker wheels (5), Figure 16 and 17, from the planter drive shafts before attaching the seed hoppers and duplex hopper.*

- a. Remove the long pipe (1), Figure 17, from between the left and right hopper drive shafts by removing the cotter pins (6), Figure 16, and (2), Figure 17.
- b. Compress the spring (2), Figure 16, on

the sliding half of the clutch and drive the pin (1) out of the shaft.

- c. Remove the cotter pins from the pinion gear (3) and from the picker wheel (5), Figure 16, and slide the shaft (4) to the left.
- d. Remove the picker wheel (5), Figure 16, and replace with the spacer washer (4), Figure 15, provided with the attachment.
- e. Slide the shaft (4), Figure 16, into former position, secure the pinion gear with the cotter pin and replace the pin in the sliding half of the clutch.
- f. Remove the cotter pin (6), Figure 17, from the right end of the shaft, and the pins holding the right picker wheel (5) and pinion gear (3).

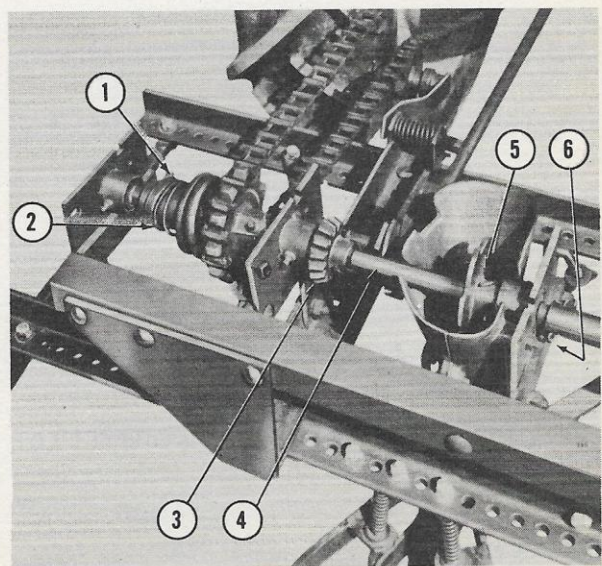

Figure 16

Left Picker Wheel

ASSEMBLY

g. Slide the shaft (4), Figure 17, to the left, remove the picker wheel (5) and replace with the spacer washer provided.

h. Slide the shaft (4), Figure 17, into former position, replace the cotter pin (6) on the right end of the shaft (4) and secure the pinion gear (3) with the cotter pin.

i. Replace the long pipe (1), Figure 17, and secure with the cotter pins.

j. Place the ring gears (8), Figure 11, and desired corn plates (4) on the seed hopper bottoms (9).

k. Place the desired bean plates (3), Figure 15, on the seed hopper bottoms with the driving lugs down.

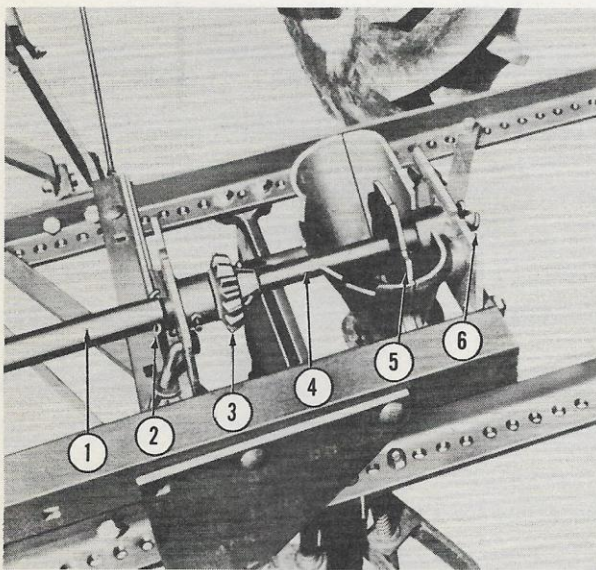

Figure 17

Right Picker Wheel

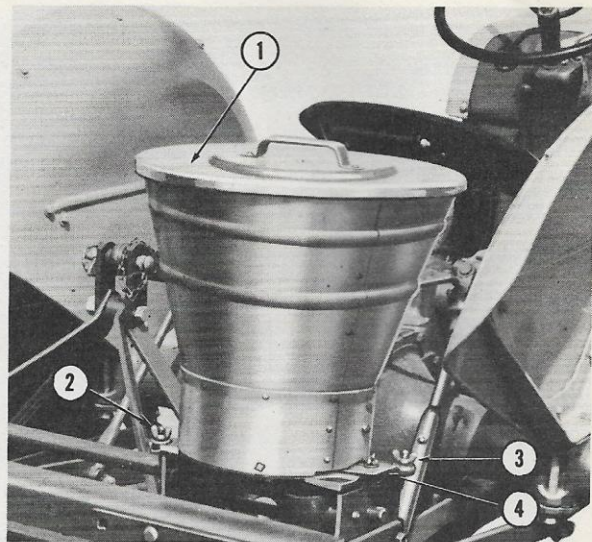

Figure 18

Seed Hopper Attached

l. Position the Duplex Hoppers (1), Figure 15, on the seed hopper bottoms with the knocker assembly (2) over the slide gauge (4), Figure 18.

m. Secure the assembly with the collar (6), Figure 11, and the wing nut (5).

16. Position the seed hoppers (1), Figure 18 over the right and left seed hopper drive assemblies and secure with the wing nuts (2) and (3).

PROCEDURE FOR ASSEMBLING THE KELLY FERTILIZER ATTACHMENT (MODEL 12-16)

1. Remove the right hand seed hopper from the planter and the cotter pins from each end of the long pipe (1), Figure 17.

ASSEMBLY

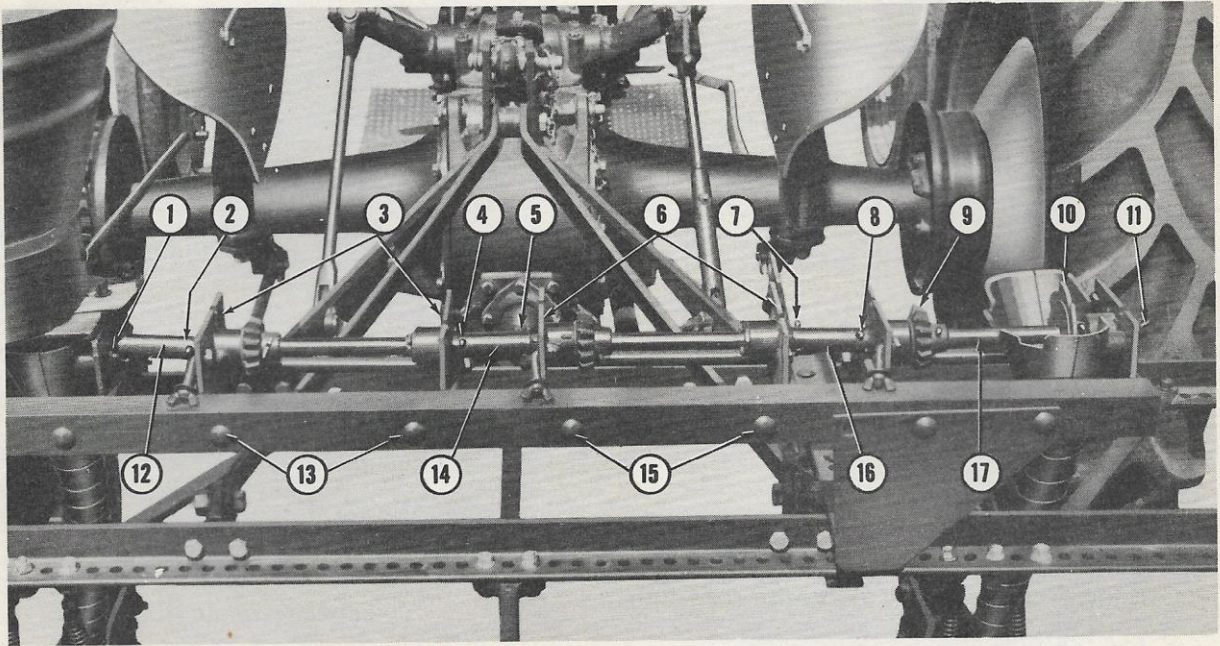

Figure 19

Fertilizer Base Assemblies Attached to Planter

2. Remove the cotter pins from the pinion gear (9), picker wheel (10) and the right end of the drive shaft (11), Figure 19.
3. Slide the driveshaft (17), Figure 19, to the right, remove the long pipe and attach two fertilizer bases to the planter main frame as follows:
 - a. Attach the left hand fertilizer base (3) to the planter angle with the bolts (13) as shown in Figure 19. Do not tighten the bolts at this time.
 - b. Place the short pipe (12) between the drive shafts and secure with the cotter pins (1) and (2), Figure 19.
 - c. Attach the right hand fertilizer base (6) to the planter angle with the bolts (15) as shown in Figure 19. Do not tighten the bolts at this time.
 - d. Place the short pipe (14) between the fertilizer-base drive shafts and secure with the cotter pins (4) and (5), Figure 19.
 - e. Tighten the nuts on bolts (13) and (15), Figure 19, and secure the left end of the short pipe (16) with the cotter pin (7).
 - f. Drive the right hopper drive shaft (17) into former position and secure each end of the shaft with the cotter pins (8) and (11), Figure 19.
 - g. Secure the pinion gear (9) and the picker wheel (10), Figure 19, with the cotter pins.

ASSEMBLY

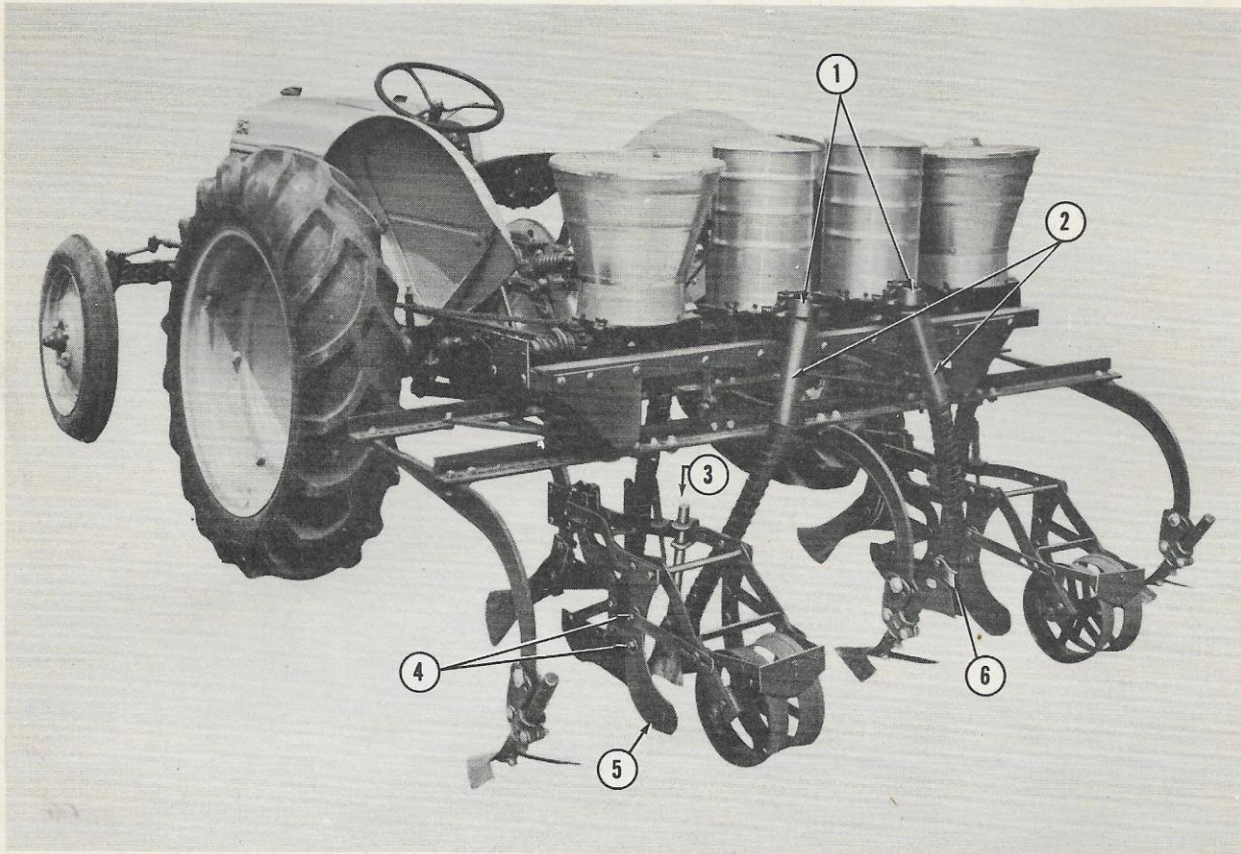

Figure 20

Kelly Planter and Fertilizer Attachment on the Cultivator Frame

4. Replace the right hand seed hopper and attach one fertilizer hopper to each base in the same manner. See Figure 20.
5. Attach one fertilizer tube (2) to each fertilizer hopper outlet (1) with the bolt and nut provided on the tube as shown in Figure 20.
6. Attach one fertilizer opener (3) to each covering frame as shown in Figure 20.
 - a. Secure the lower end of the fertilizer tube with the tube clamp (6) on each fertilizer opener.

NOTE: The fertilizer hoppers may be attached with the seed outlets (1), Figure 20, facing the tractor. In this way the operator can quickly note any clogging in the tubes or when the cans are empty. For this setup the fertilizer tubes are easily threaded between the frames and back to the openers.

PROCEDURE FOR MOUNTING PLANTER ON MIDDLEBUSTER

1. Prepare the tractor and attach the drive sprocket, the throwout rod bracket and the

ASSEMBLY

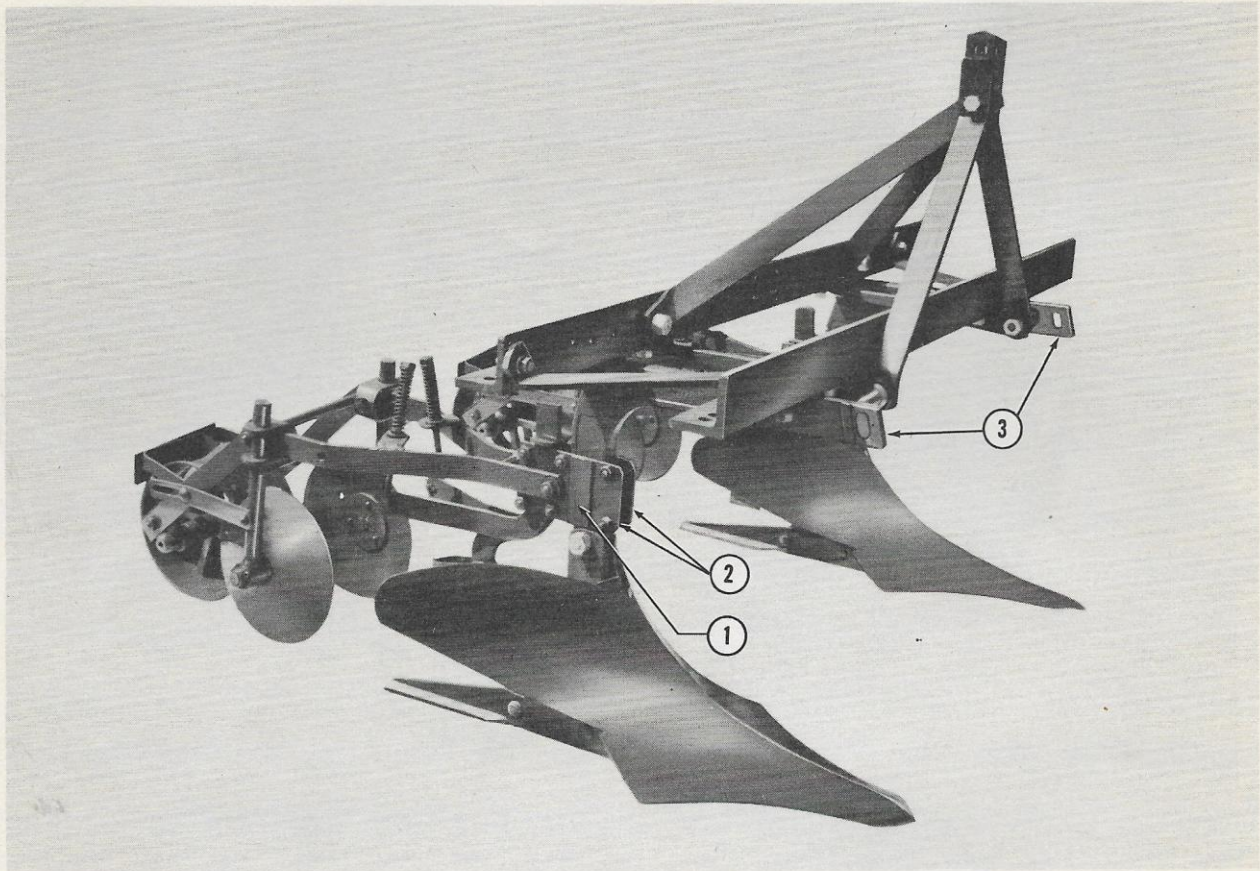

Figure 21

Covering Assemblies Attached to Middlebuster Beams

- stabilizer brackets as outlined in Steps 1, 2 and 3, Page 3.
2. Attach the middlebuster to the tractor using the standard three point hook-up.
 - a. Attach the stabilizer bars to the brackets under the tractor rear axles and to the middlebuster lower link pins.
3. Adjust the middlebuster beams (3), Figure 21, at the desired row width. Be sure the beams are spaced equally from the center of the frame.
4. Reverse the clamp bracket plates (2), Figure 21, on each covering assembly so the welded spacers (1) are on the outside of the beams, as shown.
5. Attach the covering assemblies to the beams (3), Figure 21, and secure with the carriage bolts as shown. Attach the covering assemblies as low as possible on the beams (3), Figure 21, for proper operation.
6. Assemble the planter main frame assembly as outlined in Step 10, Pages 5 and 6.

ASSEMBLY

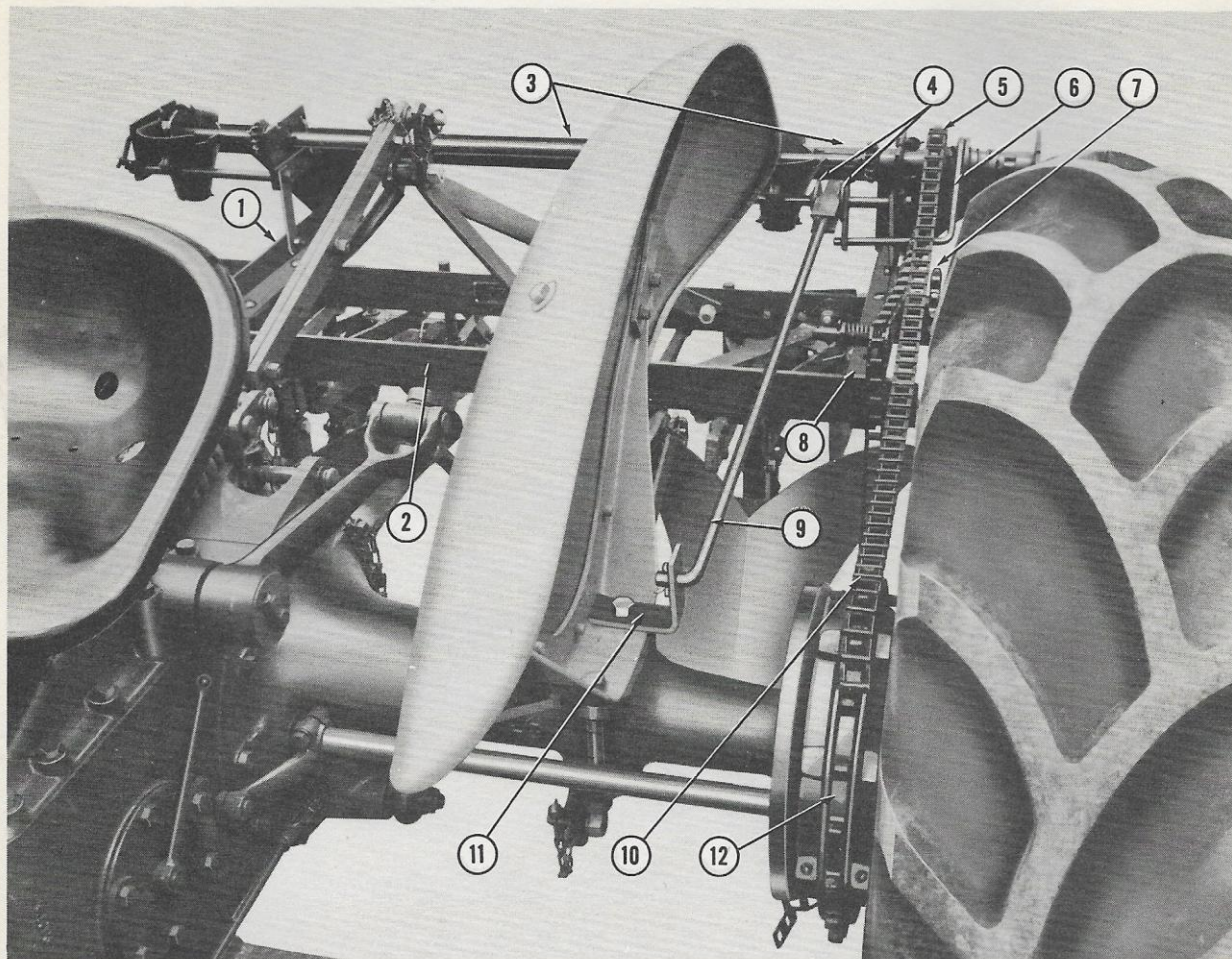

Figure 22

Assembly of Main Frame, Throwout Rod and Drive Chain

7. Attach the planter main frame assembly to the middlebuster frame as follows:

a. Remove the lower clamp bars and the long bolts from the right and left main frame support angles.

b. Place the planter main frame (3), Figure 22, on top of the middlebuster frame so the forward end of each support angle (1) and (8) rests on the front angle (2) of the middlebuster frame and the clutch

sprocket (5) is aligned with the drive sprocket (12).

c. Replace the lower clamp bars under the middlebuster frame angles and directly below the support angles (1) and (8), Figure 22. Secure with the long bolts and nuts.

8. Place the drive chain (10) on the clutch sprocket (5), Figure 22, and run the chain forward over the drive sprocket (12) on the tractor brake drum.

ASSEMBLY

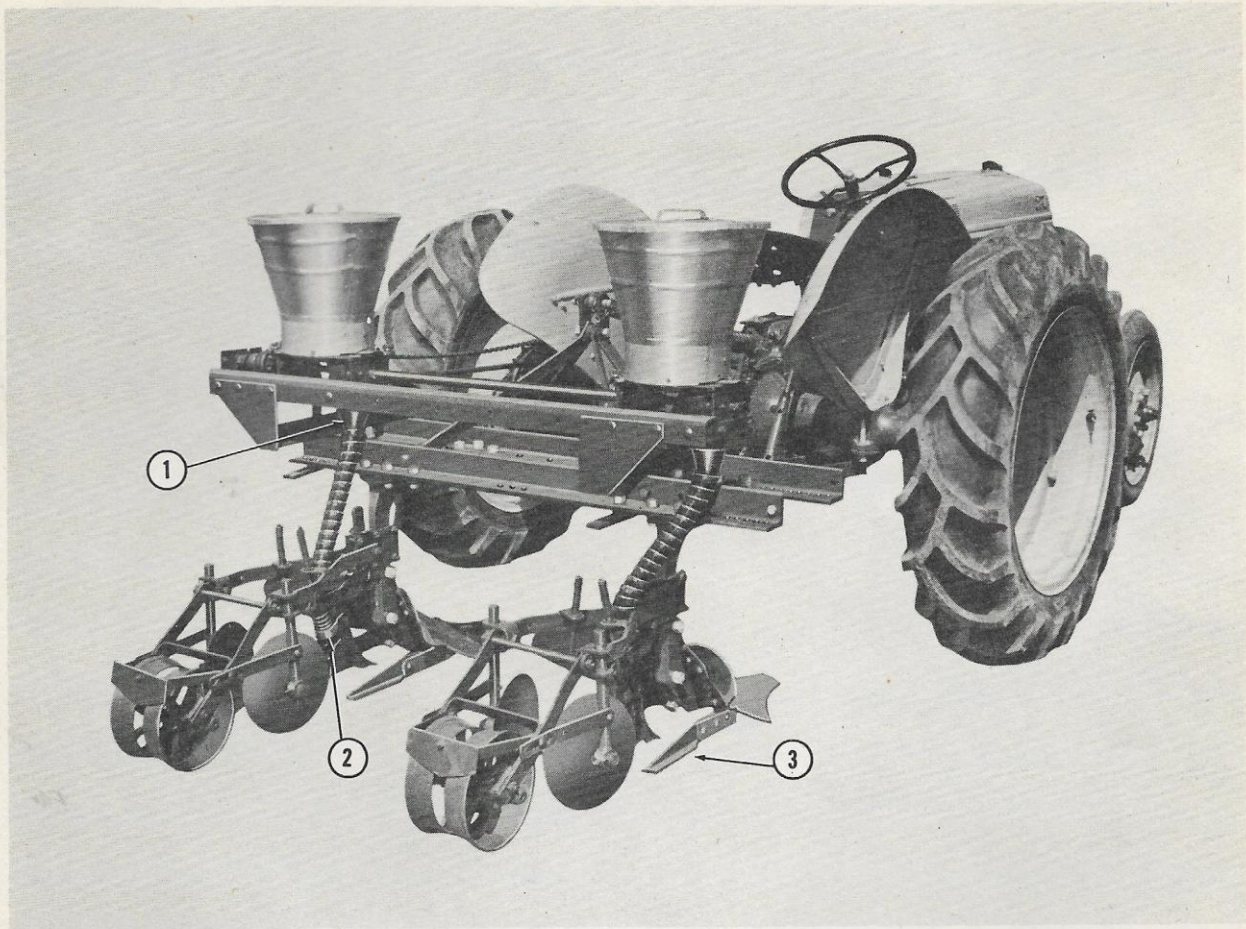

Figure 23

Kelly Planter Attachment on the Middlebuster

- a. Remove extra links as necessary to give the chain proper length and tension.
 - b. Link ends of the chain together. Be sure slack side of the chain is over the clutch shift bar (6), Figure 22.
 - c. Position the chain idler (7), Figure 22, forward and under the slack side of the chain as shown in Figure 24.
9. Insert the tapered end of the clutch throw-out rod (9) between the two large washers (4), Figure 22, on the left hand hopper horizontal support.
 - a. Insert the forward end of the throwout rod (9) in the hole on the bracket (11) as shown in Figure 22, and secure with the cotter pin.
 10. Place the collar end of each grain tube (1), Figure 23, on each grain spout. Push the collar up and turn to the right to lock in place.

ASSEMBLY

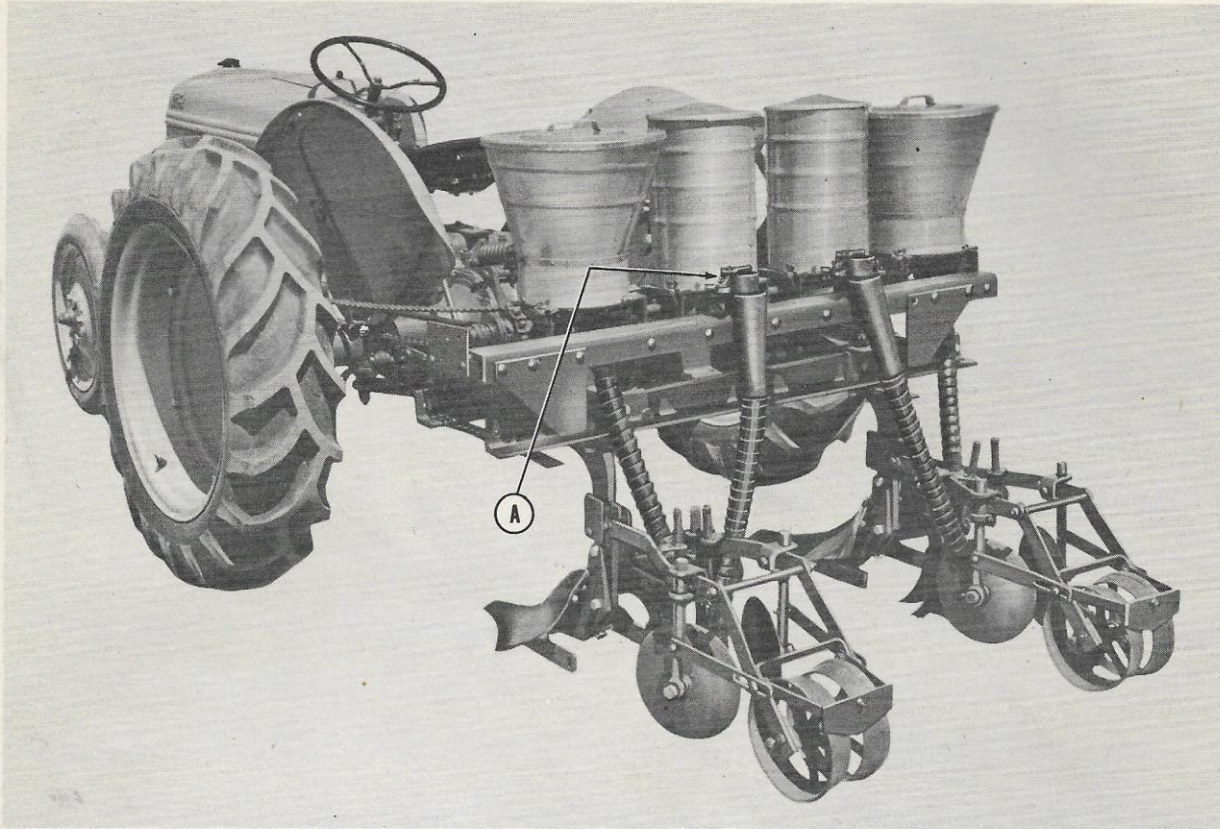

Figure 24

Kelly Planter and Fertilizer Attachment on the Middlebuster

- a. Secure the lower end of each grain tube with the clamp (2), Figure 23, provided on each opener.

NOTE: For the desired seed hopper assembly and attaching the seed hoppers, see Steps 15 and 16. To mount the fertilizer attachment on the middlebuster see Assembly Procedure on Pages 12 and 13. When the Kelly Planter and fertilizer attachment is mounted on middlebuster the runners (3), Figure 23, if the implement is equipped with them, must be removed. This will allow space for the fertilizer opener (A), Figure 25.

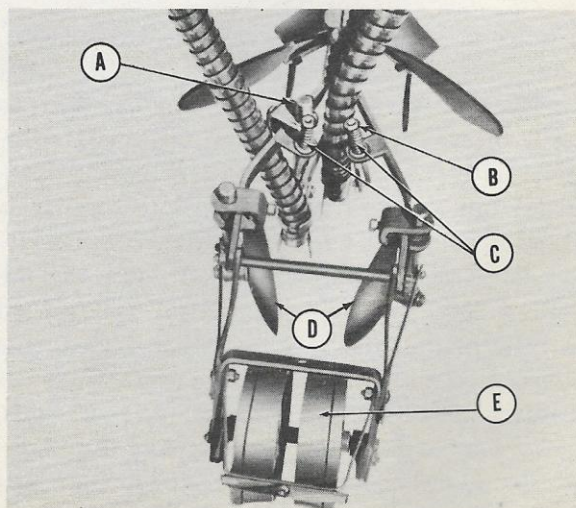

Figure 25

Fertilizer Opener Attached to Covering Assembly

OPERATION



Figure 26

Kelly Planter Attachment at Work

The Kelly Planter Attachment is well suited for planting a variety of drilled crops such as corn, beans, peas, cotton, peanuts and sorghum. The planter attachment is easily operated from the seat of the Ford tractor. It is raised or lowered with the Ford Tractor's Hydraulic Touch Control. When lowered, the chain-driven planting mechanism is engaged and the planter drops seeds; when raised, it is disengaged and stops dropping seeds. This lift feature permits easy turning at row ends, backing in to field corners, controls the planting depth and enables the operator to transport the implement to and from the field with all ground engaging parts raised free and clear of the ground.

Proper setting and adjustment assure efficient planter operation. The following information on lubrication, adjustments and maintenance is provided to aid the operator in getting maximum use from the Kelly Planter Attachment.

LUBRICATION

The Model 12-9 and Model 12-12 Kelly Planter attachments have seven grease fittings: one on each of the five drive shaft bearings, one on the clutch sprocket, and one on the chain idler sprocket.

The Model 12-10 and Model 12-11 Kelly Planter Attachments have the following four

OPERATION



Figure 27

Kelly Planter Attachment in Transport

grease fittings in addition to the seven listed in the preceding paragraph: one on each disc coverer bearing.

Fittings must be greased and the sliding half of the clutch assembly oiled before first operation of the planter and after every eight hours of operation.

ADJUSTMENTS

Covering Frames: To apply more pressure to the coverers (D) and press wheels (E), Figure 25, tighten the adjusting nut (B) on each covering frame spring (C).

To raise or lower the opener shaft (2), Figure 7, loosen the nuts on all bolts going through the clamp bracket plates (3). Set the opener at the desired depth and tighten the nuts.

To raise or lower the forward end of the sword type opener (5), Figure 7, loosen the nut on bolt (4), set the opener at the desired angle and tighten the nut. To adjust the spoon type coverers (5), Figure 20, loosen the nuts on bolts (4), set the coverer at the desired angle and tighten the nuts.

Sweeps: When the planter attachment is mounted on the cultivator frame, and sweeps (6) Figure 5, are used to clean the furrow, the angle and depth of the sweeps may be adjusted by loosening the nuts on bolts (8), set the sweeps, and tighten the nuts.

Seed Hoppers: When planting corn, maize, sorghum, peas, peanuts or beans, close the slide gauge (A), Figure 11, and secure with the wing nut.

OPERATION

When planting cotton close the slide gauge (A), Figure 13, until it almost touches the picker wheel and secure with the wing nut.

When planting corn and beans with the Duplex Hopper Attachment, open the slide gauge (A), Figure 11, and secure with the wing nut.

Fertilizer Hoppers: To control the flow of fertilizer when the fertilizer attachment is used on the Kelly Planter, loosen the wing nut (A), Figure 24, on the fertilizer hopper discharge gate. Set the gate at the desired opening and secure with the wing nut.

CAUTION: *Be sure to keep hoppers cleaned out when not in use.*

MAINTENANCE

1. Keep all cutting edges sharp.
2. Clean the planter attachment after each use and cover the ground engaging surfaces with a good grade of rust preventive.
3. Keep all nuts tight.
4. Store the planter attachment in a clean dry place.
5. Use touch-up paint as necessary to prevent rust and maintain appearance of the implement.
6. Replace worn parts promptly. Your Dearborn dealer stocks a supply of genuine Ford Tractor and Dearborn Equipment repair parts. These parts are manufactured and inspected to assure high quality and accurate fit. Insist on genuine Ford Tractor and Dearborn Equipment repair parts.

SAFETY PRECAUTIONS

Most farm implement accidents can be avoided by following these simple safety precautions:

1. Extreme care should be taken when making adjustments near cutting edges of the implement.
2. Never attempt to make adjustments on the tractor or implement when the tractor is in motion.
3. Do not permit anyone but the operator to ride the tractor at any time.
4. The operator should never get off the tractor while it is in motion.
5. Always lower the implement to the ground and shut off the tractor engine when leaving the tractor.

**HERE ARE SOME OF THE IMPLEMENTS IN THE
DEARBORN FARM EQUIPMENT LINE:**

MOLDBOARD PLOWS

DISC PLOWS

TWO-WAY PLOWS

MIDDLEBUSTERS

SINGLE DISC HARROWS

TANDEM DISC HARROWS

SPRING TOOTH HARROWS

SOIL PULVERIZERS

SUBSOILERS

LISTED CROP CULTIVATORS

SPRING SHANK CULTIVATORS

RIGID SHANK CULTIVATORS

FIELD CULTIVATORS

FOUR ROW WEEDERS

ROTARY HOES

LISTER PLANTERS

BUSTER PLANTERS

MOWERS

SWEEP RAKES

CORN PICKERS

CORN SNAPPERS

COMBINES

LOADERS

SCOOPS

BLADES

SCRAPERS

WAGONS

POST HOLE DIGGERS

DISC RIDGERS

SNOW PLOWS

Your dealer will be glad to come to your farm and, without obligation, demonstrate any equipment that interests you. Other equipment is constantly being developed and added to the Dearborn line.

SEE YOUR LOCAL FORD TRACTOR DEALER

Ask for a Demonstration

DEARBORN MOTORS CORPORATION EQUIPMENT WARRANTY

DEARBORN MOTORS CORPORATION warrants all parts (other than tires) of equipment bearing the trade mark "Dearborn Equipment" to the original purchaser thereof at retail, for a period of six (6) months from the date of delivery thereof to the original purchaser at retail, to be free from defects in workmanship and material under normal use and service. The obligation of Dearborn Motors Corporation under this warranty shall be limited to shipment, without charge to the original purchaser at retail, of the part or parts of such Dearborn Equipment intended to replace the part or parts acknowledged by Dearborn Motors Corporation to be defective in workmanship or material. This warranty is in lieu of all other warranties, expressed or implied, and of all obligations or liabilities on the part of Dearborn Motors Corporation, and it neither assumes nor authorizes any person to assume for it, any other obligation or liability in connection with workmanship or material of equipment bearing the trade mark "Dearborn Equipment" or any part thereof. This warranty shall not apply to any Dearborn Equipment, or any part thereof, which has been damaged in any accident, or by fire, flood, or Act of God, or abused or misused, or which has been altered elsewhere than at the place of manufacture, or in which the original purchaser thereof at retail, has used or allowed to be used, parts not made or supplied by Dearborn Motors Corporation. Dearborn Motors Corporation reserves the right at any time to make changes in the design, materials and/or specifications of equipment bearing the trade mark "Dearborn Equipment" and/or accessories therefor, without thereby becoming liable to make similar changes in equipment bearing the trade mark "Dearborn Equipment" and/or accessories therefor, previously manufactured.

DEARBORN MOTORS CORPORATION
DETROIT 3, MICHIGAN